



Description & Features:

- Solid front, pressure relief back, welded to a 316L stainless steel one-piece diaphragm seal body
- 316L stainless steel diaphragm for use on most corrosive media
- Permanently enclosed silicone filled system
- Field-fillable gauge
- Orifice restrictor available for severe pulsation
- Pin stop at 6 o'clock available
- ASME B40.100 compliant
- CRN registered
- 5 year warranty on gauge and seal

Applications:

- Process industry where tamper-resistant gauge/seal is required to protect against maintenance errors in the field
- Suited for installations in process, oil and gas, petrochemical and chemical industries
- Tamper resistant construction controls leaks and protects against field errors

Specifications - Gauge

Dial	4.5" (115mm) white aluminum with black and red markings
Case	Black phenolic with pressure relief back, solid front, integral back flange
Solid Wall	Phenolic
Pressure Relief Back	Polypropylene
Window	Polycarbonate
Ring	Phenolic
Pointer	Aluminum, anodized black, micrometer adjustable
Socket	316L SS
Bourdon Tube	316L SS, drawn seamless
Movement	304 SS with protective under and overload stops
Gasket Materials	Silicone (FKM option)
Welding	TIG
Over-pressure Limit	25% for pressures up to 1,450 psi (9,998 kPa), 15% for pressures 1,451 psi to 5,000 psi (9,998 kPa to 34,474 kPa)
Working Pressure	Maximum 75% of full scale value
Ambient Temperature	Dry: -40°F to 250°F (-40°C to 120°C)
Process Temperature	Silicone Filled: -49°F to 302°F (-45°C to 150°C)
Accuracy	±1% ANSI/ASME Grade A
Enclosure Rating	IP65

Specifications - Seal

Housing	AISI 316 SS
Diaphragm	AISI 316L SS, welded
Minimum Operating Pressure	15 psi (103 kPa)
Maximum Operating Pressure	2,500 psi to 5,000 psi (17,237 kPa to 34,474 kPa)
Process Connection	1/2" NPTM
System Fill	Silicone oil KF96 50CS

Order Codes

Connection	1/2" Bottom
Socket, Tube	SS
0/15 psi	PTR5061R1
0/30 psi	PTR5062R1
0/60 psi	PTR5063R1
0/100 psi	PTR5064R1
0/160 psi	PTR5065R1
0/200 psi	PTR5066R1
0/300 psi	PTR5067R1
0/400 psi	PTR5068R1
0/600 psi	PTR5069R1
0/1,000 psi	PTR5070R1
0/1,500 psi	PTR5071R1
0/2,000 psi	PTR5072R1
0/3,000 psi	PTR5073R1
0/5,000 psi	PTR5074R1

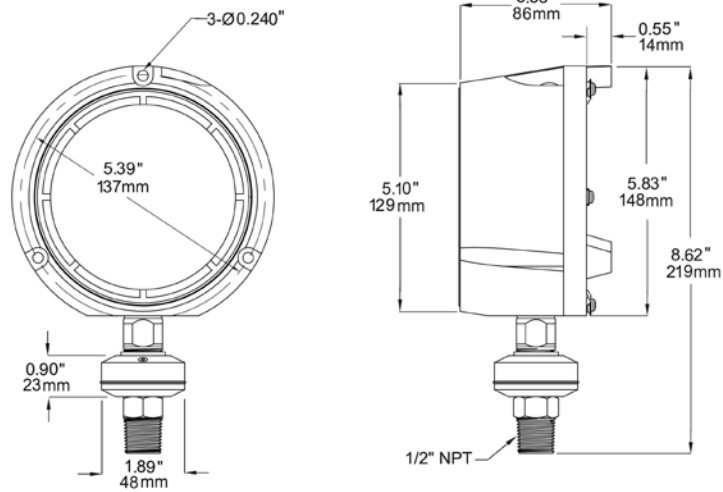

Other ranges and connection sizes (3/4" NPTM, 1" NPTM, 1/2" NPTF) available upon request. Other fills available. Pin stop at 6 o'clock position available. **For options, attach suffix to end of order code: i.e. PTR5070-SF45 for SILICONE-FILLED GAUGE CASE.**

Option suffix:

G = Glycerin-filled gauge case
 RS = Orifice restrictor for severe pulsation
 SF45 = Silicone-filled gauge case
 SG-45 = Safety glass

TAG = Stainless steel tagging
 TC = NIST test certificate of calibration
 ZR = StabilizR™ movement